

Maxseal Solenoid Operated Valves



ICO3S
1/4" 3/2
PBMR



- Typical Applications
- 1/4" 3/2 PUSH BUTTON MANUAL RESET
- Actuator Control
- Direct Acting Shut Off Valve
- Oil & Gas Applications
- Turbine Fuel Control

Thompson Valves Ltd

- Description
- Model ICO3S 1/4" 3/2 UNI
- Direct Acting Solenoid Valve
- High Flow
- Max Inlet Pressure 12 bar (174 psi)
- A direct acting solenoid operated valve for the control of pneumatic or hydraulic operated equipment
- Reliable and long life, ideal for a one time installation
- ATEX, CSA, GOST K & R and IECEx

Standard Features

Solenoid Materials of Construction	<input type="checkbox"/>	Solenoid Pot - Stainless Steel - BFC 316
	<input type="checkbox"/>	Top Cover - Stainless Steel- BFC 316
	<input type="checkbox"/>	Valve Body & Trim Materials - 316 Stainless Steel
	<input type="checkbox"/>	O-Rings Seats & Seals - Nitrile (NBR)
	<input type="checkbox"/>	Coil Insulation - Class H
Maximum Inlet Pressure	<input type="checkbox"/>	12 bar (174 psi)
Flow Rates	<input type="checkbox"/>	$C_V = 0.6$ USgpm for 1 psi Δp
	<input type="checkbox"/>	$K_V = 8.64$ l/min for 1 bar Δp
Temperature Ratings	<input type="checkbox"/>	Media (Min/Max -20°C/90°C) - Ambient (Min/Max -50°C/60°C)
Valve Size	<input type="checkbox"/>	1/4" Poppet Valve
Process Connections	<input type="checkbox"/>	1/4" NPT
Conduit Connection	<input type="checkbox"/>	M20 x 1.5 Conduit Thread
Media	<input type="checkbox"/>	Liquid & Gases
Weight	<input type="checkbox"/>	2.5 kg

Recommended Spares Kits

Soft Spares (O-rings, Springs, etc.)	<input type="checkbox"/>	Standard	Y013P01H000-SS
	<input type="checkbox"/>	Low Temperature valves	See Valve Data Sheet
Spare Coil Assembly	<input type="checkbox"/>	Standard 24V DC (3.0W)	Y01300101B0
	<input type="checkbox"/>	Other Variations	See Valve Data Sheet

Options

Valve Body & Trim Materials	<input type="checkbox"/>	Please call for details
Low Temperature Options	<input type="checkbox"/>	Please call for details
High Temperature Options	<input type="checkbox"/>	Please call for details
Process Connections	<input type="checkbox"/>	Thread 1/4" BSPP
Conduit Connection	<input type="checkbox"/>	1/2" NPT
Extreme Service	<input type="checkbox"/>	Increased Power Consumption - Please call for details
Product Lead Time	<input type="checkbox"/>	Y013PA1H1BS - 1 week (subject to quantities)
	<input type="checkbox"/>	Other variations: Please call for possible delivery dates

Technical Specification

Pressures

Test (Proof) Pressure	<input type="checkbox"/> 15 bar (218 psi)
Maximum Inlet Pressure	<input type="checkbox"/> 12 bar (174 psi)
ATEX Classification	<input type="checkbox"/> Complies with ATEX Directive 94/9/EC
ATEX Certificate	<input type="checkbox"/> SIRA 00ATEX1156 and SIRA 05 ATEX 5284
Certification 	<input type="checkbox"/> II 2GD <input type="checkbox"/> Ex d IIC T6 (T _a = -60°C to + 50°C) or <input type="checkbox"/> Ex d IIC T4 (Max Ambient = + 90°C) <input type="checkbox"/> Ex mbe IIC T4 (T _a = -60°C to + 80°C)
IECEX Certificate	<input type="checkbox"/> IECEX SIR 05.0029 and IECEX SIR 05.0056
IECEX	<input type="checkbox"/> Ex d IIC T6 (T _a = -60°C to + 50°C) or <input type="checkbox"/> Ex d IIC T4 (Max Ambient = + 90°C)
GOST 'K'	<input type="checkbox"/> Ex d IIC T6 (T _a = -60°C to + 50°C)
GOST 'R'	<input type="checkbox"/> Ex d IIC T6 (T _a = -60°C to + 50°C)
Safety Integrity Level	<input type="checkbox"/> SIL 3 or SIL 4 (SIL 4 in redundant configuration only)
Ingress Protection	<input type="checkbox"/> IP66/X8 to BS EN 6052:1992, NEMA 4X
Voltage Surge Protection	<input type="checkbox"/> Surge Suppression Diodes
Coil Insulation	<input type="checkbox"/> Class H

Performance

Pull-In Voltage	<input type="checkbox"/> 87.5% of Nominal
Response Times	<input type="checkbox"/> Pull-In <80 ms <input type="checkbox"/> Drop-Out <60 ms
Electromagnetic Compatibility (EMC)	<input type="checkbox"/> EN50081-1 EN50082-1 EN61000-4 parts 2,4,5

Valve Symbol

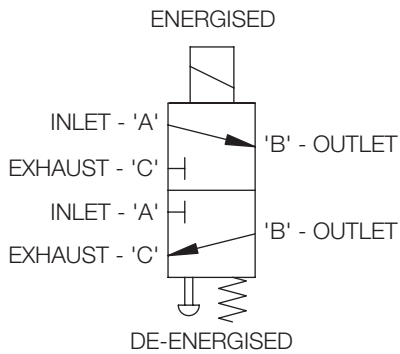

VALVE SYMBOL FOR
ENERGISE TO OPEN
(DE-ENERGISED TO CLOSE)
(NORMALLY CLOSED)

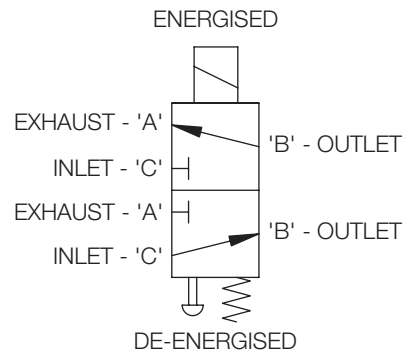

VALVE SYMBOL FOR
ENERGISE TO CLOSE
(DE-ENERGISED TO OPEN)
(NORMALLY OPEN)

Ordering Information

Model	Operating Pressure	Port Config.	Operation	Process Conn.	Seat/Seal Materials	Conduit Connection	Voltage	Body/Trim Materials
Y0	1	3	P	A1	H	1	B	S
Y0 ICO3S Ex d	0-12 barg (174 psi)	3/2 UNIVERSAL	PBMR	A1 1/4" NPT	H Nitrile	1 M20 x 1.5	B 24V DC	S 316 SS / 316 SS
YZ ICO3S Ex mbe				E1 1/4" BSPP	V Viton®	2 1/2" NPT	E 125V DC	

Ordering Example

Y0	1	3	P	E1	V	2	E	S
ICO3S Ex mbe	0-12 barg (174 psi)	3/2 UNI	PBMR	1/4" BSPP	Viton®	1/2" NPT	125V DC	316 SS / 316 SS

Power Consumption (At Nominal)

DC Standard	
24V DC	3.0W
125V DC	3.0W

AC Standard
Please Call for Information

Extreme Service
Please Call for Information

Profile and Dimensions mm

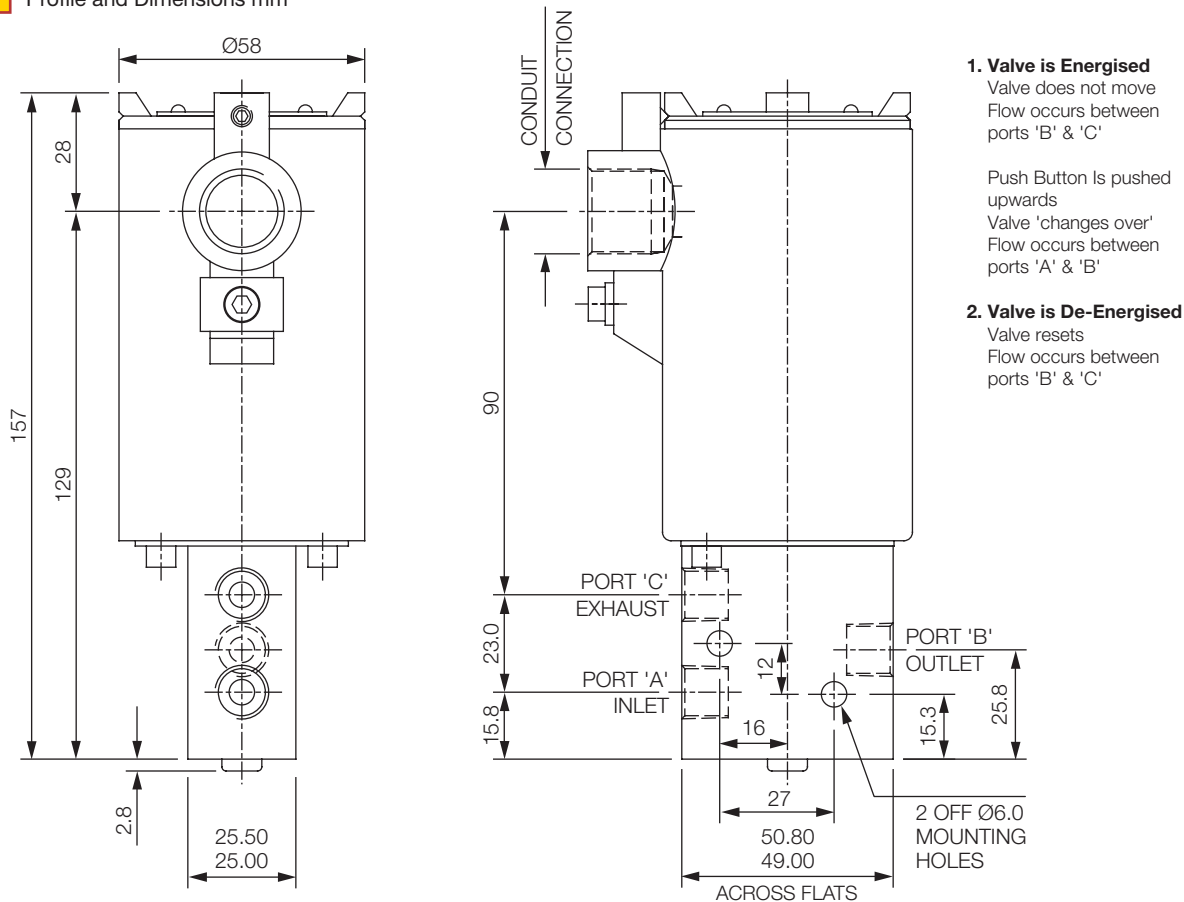

Thompson Valves reserves the right to amend product specifications or designs without notice. Information is given in good faith and no liability can be accepted for error or omission. Viton® is a registered trademark of DuPont Performance Elastomers.