

# Maxseal Solenoid Operated Valves



ICO4S  
1/2" 3/2  
PBMR



## Typical Applications

- 1/2" 3/2 PUSH BUTTON MANUAL RESET
- Actuator Control
- Direct Acting Shut Off Valve
- Oil & Gas Applications
- Turbine Fuel Control

## Thompson Valves Ltd

### Description

- Model: ICO4S 1/2" 3/2 PBMR Direct Acting Solenoid Valve
- Low Pressure, High Flow
- Max Inlet Pressure 20 bar (290 psi)
- Reliable and long life, ideal for a one time installation
- Control of pneumatic or hydraulic operated equipment

<b>Standard Features</b>	<input type="checkbox"/> ICO4S 1/2" 3/2 PBMR
<b>Solenoid Materials of Construction</b>	<input type="checkbox"/> Solenoid Pot - Stainless Steel - BFC 316
	<input type="checkbox"/> Top Cover - Stainless Steel- BFC 316
	<input type="checkbox"/> Valve Body & Trim Materials - 316 Stainless Steel
	<input type="checkbox"/> O-Rings Seats & Seals - High Nitrile (NBR)
	<input type="checkbox"/> Coil Insulation - Class H
<b>Maximum Inlet Pressure</b>	<input type="checkbox"/> 20 Bar (290 PSI)
<b>Flow Rates</b>	<input type="checkbox"/> $C_v = 4.2$ USgpm for 1 psi $\Delta p$
	<input type="checkbox"/> $K_v = 46$ l/min for 1 bar $\Delta p$
<b>Temperature Ratings</b>	<input type="checkbox"/> Media (Min/Max -20°C/90°C) - Ambient (Min/Max 0°C/60°C)
<b>Valve Size</b>	<input type="checkbox"/> 1/2" Balanced Poppet Valve
<b>Process Connections</b>	<input type="checkbox"/> 1/2" NPT
<b>Conduit Connection</b>	<input type="checkbox"/> M20 x 1.5 Conduit Thread
<b>Media</b>	<input type="checkbox"/> Liquid & Gases
<b>Weight</b>	<input type="checkbox"/> 7.5 Kg

<b>Recommended Spares Kits</b>		
<b>Soft Spares (O-rings, Springs etc)</b>	<input type="checkbox"/> Standard (Viton® & High Nitrile)	Y123A030000-SS
	<input type="checkbox"/> Low Temperature valves	See Valve Data Sheet
<b>Spare Coil Assembly</b>	<input type="checkbox"/> Standard 24V DC (4.5 Watts)	Y123P0301B0
	<input type="checkbox"/> Other Variations	See Valve Data Sheet

<b>Options</b>	
<b>Valve Body &amp; Trim Materials</b>	<input type="checkbox"/> Aluminium Bronze - Sea Water Applications
	<input type="checkbox"/> Titanium - Extreme Service Applications
<b>Low Temperature Options</b>	<input type="checkbox"/> O-Rings - Low Nitrile/Fluorosilicone (Min Med/Amb -40°C/-40°C)
<b>High Temperature Options</b>	<input type="checkbox"/> High Temperature Spacer (Max Med/Amb 120°C/60°C)
	Please Call for Dimensions
<b>Process Connections</b>	<input type="checkbox"/> Thread - 1/2" BSPP
<b>Conduit Connection</b>	<input type="checkbox"/> 1/2" NPT
<b>Product lead time</b>	<input type="checkbox"/> Y123PA3H1BS - 2 WEEKS (SUBJECT TO QUANTITY)
	<input type="checkbox"/> Other Variations - Please call for possible delivery dates

**Technical Specification**

<b>Pressures</b>	
Test (Proof) Pressure	<input type="checkbox"/> 30 bar (435 PSI)
Maximum Inlet Pressure	<input type="checkbox"/> 20 Bar (290 PSI)
<b>ATEX Clasification</b>	
ATEX Certificate	<input type="checkbox"/> Complies with ATEX Directive 94/9/EC
ATEX Certificate	<input type="checkbox"/> SIRA 00ATEX1147
<b>Certification</b>	
	<input type="checkbox"/> II 2G
	<input type="checkbox"/> EExd IIC T6 (T <sub>a</sub> = -60°C to + 48°C) or
	<input type="checkbox"/> EExd IIC T4 (T <sub>a</sub> = -60°C to + 90°C)
<b>IECEX</b>	
	<input type="checkbox"/> IECEX BAS 04.0019
	<input type="checkbox"/> EExd IIC T6 (T <sub>a</sub> = -40°C to + 60°C) or
	<input type="checkbox"/> EExd IIC T4 (T <sub>a</sub> = -40°C to + 90°C)
<b>GOST 'K'</b>	
	<input type="checkbox"/> EExd IIC T6 (T <sub>a</sub> = -40°C to + 60°C)
<b>GOST 'R'</b>	
	<input type="checkbox"/> EExd IIC T6 (T <sub>a</sub> = -40°C to + 60°C)
<b>Safety Integrity Level</b>	
	<input type="checkbox"/> Suitable for SIL 3 Application in Simplex Mode
	<input type="checkbox"/> Suitable for SIL 4 Application in Duplex Mode
<b>Ingress Protection</b>	
	<input type="checkbox"/> IP66/X8, NEMA 4X
<b>Voltage Surge Protection</b>	
	<input type="checkbox"/> Surge Suppression Diodes
<b>Coil Insulation</b>	
	<input type="checkbox"/> Class H
<b>Performance</b>	
Pull-in Voltage	<input type="checkbox"/> 87.5% of Nominal
<b>Response Times</b>	
	<input type="checkbox"/> Pull-In <150ms
	<input type="checkbox"/> Drop-Out <80ms
<b>Electromagnetic Compability (EMC)</b>	
	<input type="checkbox"/> EN50081-2/82-1

**Valve Symbol**

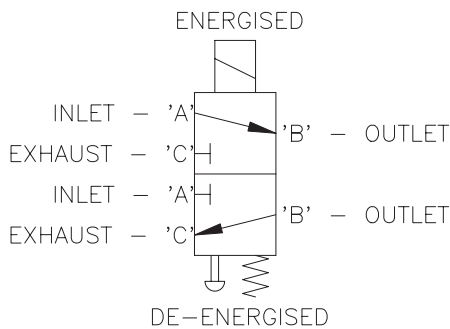

VALVE SYMBOL FOR  
ENERGISE TO OPEN  
(DE-ENERGISED TO CLOSE)  
(NORMALLY CLOSED)

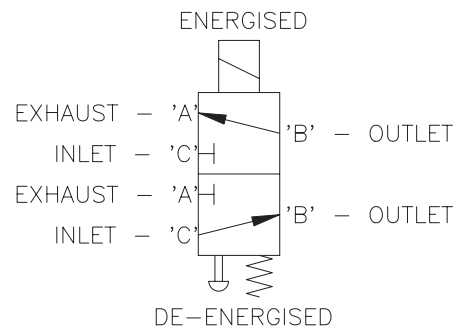

VALVE SYMBOL FOR  
ENERGISE TO CLOSE  
(DE-ENERGISED TO OPEN)  
(NORMALLY OPEN)

**Ordering Information**

Model	Operating Pressure	Port Config.	Operation	Process Connection	Seat/Seal Materials	Conduit Connection	Voltage	Body/Trim Materials				
Y1	2	3	P	A3	H	1	B	S				
ICO4S	0-20 Barg (290 psi)	3/2 UNIVERSAL	PUSH BUTTON MANUAL RESET	A3	H	1	A 18/33V DC	S 316 SS / 316 SS				
				1/2" NPT	High Nitrile	M20x1.5	B 24V DC	M Alu Brnz / Alu Brnz				
				E3	V	2	C 50V DC					
				1/2" BSPP	Viton®	1/2" NPT	D 110V DC					
											E 125V DC	3 Titanium / Titanium
											G 25V AC	
											J 110V AC	
							M 240V AC					

1/2" 3/2

**Ordering Example**

Y1	2	3	P	E3	V	1	A	M
ICO4S	0-20 Barg (290 psi)	3/2 UNI	PBMR	1/2" BSPP	VITON®	M20 x 1.5	18/33V dc	Alu Brnz / Alu Brnz

**Power Consumption (At Nominal)**

DC Standard		AC Standard	
18 / 33V DC (24V DC)	7.7 W	25V AC	6.5 W
24V DC	4.5 W	110V AC	6.5 W
50V DC	5.5 W	240V AC	6.2 W
110V DC	8.0 W		
125V DC	10.4 W		

**Profile and Dimensions mm**

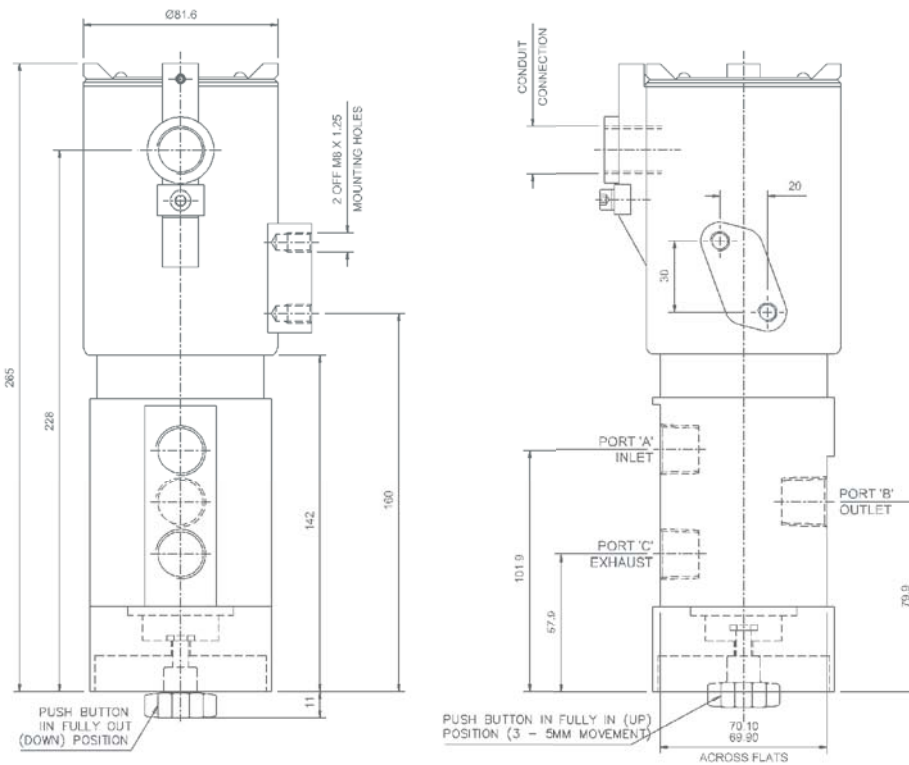

- Valve is energised  
Valve does not move  
Flow occurs between ports 'B' & 'C'  
  
Push button is pushed upwards  
Valve 'changes over'  
Flow occurs between ports 'A' & 'B'
- Valve is de-energised  
Valve resets  
Flow occurs between ports 'B' & 'C'

Thompson Valves reserves the right to amend product specifications or designs without notice. Information is given in good faith and no liability can be accepted for error or omission. Viton® is a registered trademark of DuPont Performance Elastomers.

Thompson Valves, 17 Balena Close, Creekmoor, Poole, Dorset BH17 7EF, ENGLAND  
Tel +44 (0)1202 647331 Fax +44 (0)1202 647302 Email maxseal@thompson-valves.com  
www.thompson-valves.com A fluid controls business of IMI plc