

IVP - Type K42

Installation, Operation And Maintenance Instructions MI0220

GENERAL NOTES

- THESE INSTRUCTIONS APPLY ONLY TO THE K42 SERIES.
- THE PRESSURES SUPPLYING AND CONTROLLED BY THIS PRESSURE REDUCING VALVE (PRV) ARE SUFFICIENTLY HIGH TO ENDANGER HUMAN LIFE.
- SUITABLY TRAINED, QUALIFIED AND AUTHORISED PERSONNEL MUST CARRY OUT ALL INSTALLATION AND MAINTENANCE PROCEDURES. UNAUTHORISED PERSONS MUST BE PROHIBITED FROM TAMPERING WITH, OR OPERATING THIS EQUIPMENT.
 - IT IS ASSUMED THAT THE SYSTEM INTO WHICH THIS PRV IS TO BE SET IS PROVIDED WITH ADEQUATE ISOLATION AND SAFETY DEVICES RELEVANT TO THE MEDIA BEING PROCESSED.

TECHNICAL INFORMATION

- Maximum Inlet Pressure – 40 Bar
- Hydraulic Test Pressure – 60 Bar
- Outlet Pressure Range – 0.5 – Bar
- CV – 11.4 (kV – 9.7)
- Pressure Surge – 10%
- Temperature Range – Ductile Cast Iron -20°C to +150°C

ATEX MARKING INDICATOR

MARKING (STANDARD)	DESCRIPTION
EX II 2 G D	EQUIPMENT IS SUITABLE FOR USE IN NON MINING, EX ENVIRONMENTS, GAS AND DUST
Exc IIC	NON ELECTRICAL EQUIPMENT SUITABLE FOR AN EX ENVIRONMENT
T3 Ta	T RATED EX EQUIPMENT NOT TO BE USED OUTSIDE THE SPECIFIED TEMPERATURE RANGES (Ta)
INLET, OUTLET	PIPEWORK SHOULD BE CONNECTED SUCH THAT IT FUNCTIONS AS PORT MARKINGS
SERIAL No.	FOR YEAR OF MANUFACTURE REFER TO CERTIFICATE OF CONFORMITY

ATEX SEAL TABLE

POLYMER	Ta TEMP	NON ATEX
NITRILE	-10 TO 100°C	-10 to +100°C
VITON	-20 TO 135°C	-20 TO +150°C
EPDM	-30 TO 115°C	-30 TO +115°C

1.0 DESCRIPTION

- The PRV is suitable for use in low to medium-pressure gas/liquid systems where a reduction of pressure is required.
- This valve is not considered subject to creep or fatigue within its specified operating limits
- The range of pressure reduction is infinite, and is made possible by the infinitely variable dome charging pressure.

- As standard, a 25.4-mm diameter, soft trimmed, balanced valve is fitted.
- Internal sealing is achieved with “O” rings.
- The Inlet/Outlet connections are to EN 1092-2/DN50/PN40/21-2/DI 400-18/B.
- It is recommended that connecting pipe-work be suitably supported close to the valve connections.
- It is assumed that a gauge reflecting the outlet pressure is positioned before the outlet isolation valve.
- Suitable downstream pressure relief must be incorporated.
- Approximate weight of the equipment is 18.5 Kg. therefore, the equipment may be regarded as portable.

1.1 FUNCTION

To obtain flow through a K42 PRV, it is necessary to charge its dome with an inert gas (nitrogen or air - not oxygen). Before the valve of the controller will open, the pressure in the dome must overcome the combined load of the valve spring and the inlet pressure under the valve head.

2.0 INSTALLATION

BEFORE COMMENCEMENT OF ANY INSTALLATION WORK, IT IS IMPORTANT THAT ANY SOURCE OF PRESSURISED MEDIA BE TURNED OFF OR ISOLATED FROM THE POINT AT WHICH THE PRV WILL BE INSTALLED.

DAMAGE MAY OCCUR TO THE VALVE IF SUBJECTED TO ANY IMPACT. THIS RISK INCREASES AT LOWER TEMPERATURES. IF THE VALVE IS DROPPED OR SUBJECT TO ANY IMPACT IT SHOULD BE RETURNED TO THE MANUFACTURER FOR INSPECTION.

AT ALL TIMES, IT IS ESSENTIAL THAT ISOLATING VALVES MUST BE ACTUATED SLOWLY TO AVOID THE RISK OF EXPLOSION DUE TO DIESELING.

The valve is not designed specifically to function without any effect from shock loads incurred as a result of adverse traffic, wind or seismic conditions. Any use in these areas is at user risk.

- Remove packaging and ensure that there are no obviously loose parts or visual signs of damage.
- Check that the information listed on the nameplate confirms that the PRV supplied is suitable for the intended service.
- The system into which the PRV is to be set must be clean and free of any solid inclusion that could be a source of damage to soft-seated components.
- The PRV is set directly into the line using the Flanged inlet and outlet connections.
- The two ports are diametrically opposite and it is important that the PRV is correctly oriented into the pipe-work. A Flow direction arrow is cast on the body. Other than for ease of maintenance, the angular orientation of the PRV in the line is not important.

2.1 SETTING TO WORK

- Ensure that inlet and outlet connections are leak-tight. Check with “leak detection” fluid if necessary.
- Ensure that supply and outlet isolation valves are **closed**.
- Close all needle valves.
- Gauges must be provided in the line in order that inlet and outlet pressures may be monitored during setting up.

- Ensure that **correct supply pressure** is available, before **SLOWLY** opening supply isolation valve. Outlet isolating valve remains closed.
- **Loading from the line: SLOWLY** open line loading needle valve NV 1 (See Figure 1) approximately ¼ turn anti-clockwise. Then gently open the other needle valve NV 2 and monitor pressure on the outlet gauge. This should rise as the dome is charged. When correct outlet pressure is reached, **close** needle valve NV 2 (clock-wise) and then **close** line loading needle valve NV 1. **VERY SLOWLY**, open outlet-isolating valve to run system.
- **Loading from an external supply:** Remove plug and connect suitable inert gas or air supply (see figure 1). Slowly open needle valve NV2 to charge dome at the same time monitoring pressure on outlet gauge. When correct outlet pressure is reached, **close** needle valve (clock-wise). Disconnect external supply and refit plug. **VERY SLOWLY**, open outlet-isolating valve to run system.
- **Venting dome:** Unscrew plug approximately one turn, then open needle valve NV 2 to vent dome.
- **Note that external valve surfaces may become very hot or cold during use, dependant on media.**

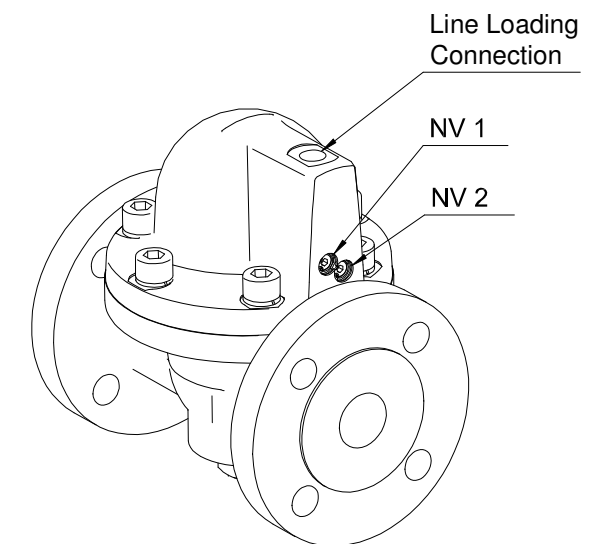

Figure 1 - Needle Valves

3.0 MAINTENANCE

- Having few moving parts, the K42 will require only periodic inspection of those items subject to wear or deterioration, to ensure long service and reliability.
- It is recommended that when servicing or repair becomes necessary the PRV be returned for factory refurbishment. However, the design of the K42 does enable servicing in the field, with minimal inconvenience, to satisfy plant operations and minimise down times.
- It is recommended that all repairs and servicing be carried out using only quality assured spares supplied by the manufacturer.

3.1 PREVENTATIVE MAINTENANCE

- In a clean system, the K42 will continue to deliver trouble free service over long periods. Under these conditions, maintenance intervals may be as long as 24-36 months. In more arduous conditions or in aggressive media service, the periods may be shorter, 6-12 months. It is however, important that units in safety related applications be inspected more frequently. During these preventative maintenance periods, the following procedure is suggested :
 - a) Inspect all “O” seals for wear, brittleness or other signs of damage. All those displaying any indication of damage or deterioration should be replaced. However, it is recommended that all seals, regardless of any damages should be routinely replaced.

- b) Remove the valve and seat and inspect closely for wear or damage. Typical signs of damage will be nicks or raised burrs around the seating edge of the seat, or indentations, abrasions and hard particle inclusions in the soft (seating) area of the valve member. Severe wear and/or very apparent nicks, burrs or particle inclusion would indicate that replacement is necessary. Light wear and the presence of a clean, continuous seating ring on both parts would indicate that they are suitable for re-use.
- c) Any components showing signs of corrosion should be inspected for indications of permanent damage (i.e. pitting etc.) and replaced if any are present.

3.2 REMEDIAL MAINTENANCE

- If the K42 is maintained to a planned programme, it is unlikely that the need for remedial service will arise. However, if the system becomes contaminated or an operating system problem causes damage to one of the control elements, the PRV may malfunction. In general it is recommended that damaged PRV's be returned to the factory for repair. To facilitate field repair, and minimise plant downtime, **Table 1** lists some possible faults and probable causes/solutions.

We also make the following recommendations:

- It is preferable that the PRV be repaired or serviced under workshop conditions, as the opened equipment must be protected from ingress of dirt and other foreign material. Should operational requirements make it necessary to service the PRV in the pipeline, then precautions should be taken to avoid contamination of the unit or parts.

SAFETY NOTE: WHEN UNDERTAKING ANY REPAIR OR SERVICING IN WHICH THE PRV REMAINS IN THE LINE, IT IS ESSENTIAL THAT THE EQUIPMENT IS ISOLATED FROM THE PRESSURISED MEDIA. IT IS ALSO IMPORTANT THAT THE DOME IS FULLY VENTED - SEE 2.1 FOR PROCEDURE.

SYMPTOM	CAUSE	SOLUTION
Rise in outlet pressure above that set.	Damaged valve and/or seat Dirty valve and/or seat Damaged valve "o" ring	Replace part(s). Clean part(s).
	Damaged seat "o" ring Valve spring failure Valve jams open	Replace part Replace part Replace part Investigate cause - replace valve if necessary
Loss of outlet pressure	Damaged diaphragm Leaking dome	Replace part. Tighten or replace part.

Table 1

4.0 STRIPPING AND RE-ASSEMBLY

Having few parts, stripping and re-assembly of the K42 may be regarded as straightforward, provided certain conditions are observed.

- Cleanliness is of the utmost importance, even the smallest of inclusions may seriously affect the operation of the PRV.

- Tool List:
Torque wrench
3 mm A/F hexagon wrench key
10 mm A/F hexagon wrench key
Large adjustable spanner
Circlip Pliers (small)
- Use only sparing amounts of grease during re-assembly. That recommended is "Dow Corning MS4", any alternative should be checked carefully. Use of greases at all, with media other than inert gases, **MUST BE CHECKED WITH LUBRICANT SUPPLIERS!**
- For safety, **all** tightening torque values **must** be adhered to. Refer to assembly drawing.

4.1 STRIPPING

- Remove M12 socket head capscrews and washers.
- Lift off dome complete with needle valves and plug taking care with small 'o' ring between the two.
- The needle valves, 'o' rings, plug (if fitted), and bonded seal can be removed.
- Working at the other end of the valve, unscrew and withdraw the body plug complete with valve, spring and 'o' rings. **Note that some residual pressure may escape during removal of the body plug.**
- At this stage the seat and 'o' ring may come out with the body plug, however if not, gently pull out with a hooked instrument.

4.2 RE-ASSEMBLY

- This is a direct reversal of stripping.
- It is important that components are clean
- Replace the dome in the correct orientation i.e. with the boss containing the needle valves facing the inlet.
- **NOTE:** On low-pressure versions of this PRV, there is a thinner diaphragm with a gasket fitted. All other components and procedures remain unaltered.

Torque figures:

M12 Socket head capscrews.....	51.4 Nm
Body Plug	60 Nm
Blanking plug	35 Nm

Manufacturer:

In the event of fire the seals on this valve may become ineffective and/or give off toxic fumes. Note that the valve is not CE marked with respect to fire service.

With respect to unstable and dangerous fluids intended for use with this valve, refer to Transport and Handling sections of the Manufacturers Safety Data Sheet for that fluid or contact FC^X Thompson Valves Technical Sales for advice.

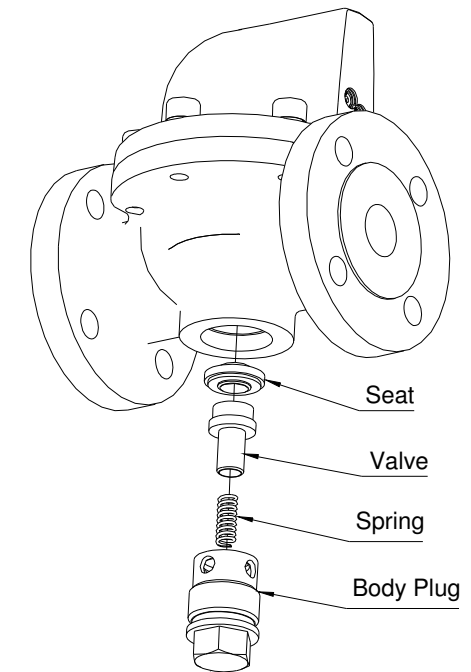

Figure 2 - Dome removal ('o' rings not shown)

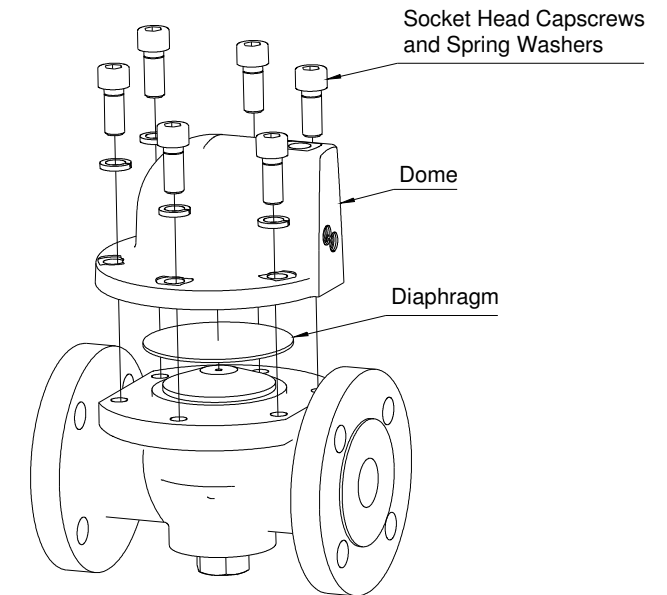

Figure 3 - Valve removal ('o' rings not shown)