

# MI0244

## IVP - Type J46

### Installation, Operation and Maintenance Instructions

#### GENERAL NOTES

- THESE INSTRUCTIONS APPLY ONLY TO THE J46 SERIES.
- THE PRESSURES SUPPLYING AND CONTROLLED BY THIS PRV ARE SUFFICIENTLY HIGH TO ENDANGER HUMAN LIFE. SUITABLY TRAINED, QUALIFIED AND AUTHORISED PERSONNEL MUST CARRY OUT ALL INSTALLATION AND MAINTENANCE PROCEDURES. UNAUTHORISED PERSONS MUST BE PROHIBITED FROM TAMPERING WITH, OR OPERATING THIS EQUIPMENT.
- IT IS ASSUMED THAT THE SYSTEM INTO WHICH THIS PRESSURER REDUCING VALE (PRV) IS TO BE SET, IS PROVIDED WITH ADEQUATE ISOLATION AND SAFETY DEVICES.
- THE VENT CONNECTION OF RELEASE OPTION (SEE TABLE \*\*) MUST NOT BE OBSTRUCTED IN ANY WAY WHICH WOULD RESTRICT THE FREE VENTING OF MEDIA TO ATMOSPHERE.
- "HAZARDOUS" MEDIA MUST NOT BE VENTED DIRECTLY TO ATMOSPHERE. THEY MUST BE PIPED, VIA THE VENT CONNECTION TO A DESIGNATED SAFETY ZONE OR CONTAINER.
- SHOULD THE PRV BE PLACED INSIDE A CONTAINER OR CABINET, THEN THE CONTAINER/CABINET MUST INCORPORATE A VENTING SYSTEM.

#### TECHNICAL INFORMATION

- Maximum Inlet Pressure – 80 Bar
- Hydraulic Test Pressure – 120 Bar
- Outlet Pressure Range:
  - 0.1 – 1.03 Bar
  - 0.3 – 5.15 Bar
  - 0.5 – 11 Bar
  - 10 – 33 Bar
- CV:
  - 3/16" : CV – 0.5 (KV – 0.43)
  - 1/4" : CV – 0.84 (KV – 0.72)
  - 3/8" : CV – 2.24 (KV – 1.9)
  - 1/2" : CV – 3.35 (KV – 2.76)
- Valve Temperature Range - -40°C to +150°C

#### ATEX MARKING INDICATOR

MARKING (STANDARD)	DESCRIPTION
EX II 2 G D	EQUIPMENT IS SUITABLE FOR USE IN NON MINING, EX ENVIRONMENTS, GAS AND DUST
Exc IIC	NON ELECTRICAL EQUIPMENT SUITABLE FOR AN EX ENVIRONMENT
T4 Ta (-10 - +100°C)	T RATED EX EQUIPMNET NOT TO BE USED OUTSIDE THE SPECIFIED TEMPERATURE RANGES (Ta)
INLET, OUTLET, VENT	PIPEWORK SHOULD BE CONNECTED SUCH THAT IT FUNCTIONS AS PORT MARKINGS
SERIAL No.	FOR YEAR OF MANUFACTURE REFER TO CERTIFICATE OF CONFORMITY

#### ATEX SEAL TABLE

POLYMER	Ta TEMP	NON ATEX
NITRILE	-10 TO 100°C	-10 TO +100°C
VITON	-20 TO 135°C	-20 TO +150°C
EPDM	-30 TO 115°C	-30 TO +115°C

#### 1.0 DESCRIPTION

- The J46 is a single stage, spring loaded, Pressure Reducing Valve (PRV), of 2.24 CV.(3/8"valve) , 3.35 (1/2") and 0.84 (1/4")
- The PRV is suitable for use in medium-pressure gas systems where a reduction of pressure is required.
- The range of pressure reduction is extremely wide, and is made possible by the availability of varying combinations of piston or diaphragm and load spring packs.
- One option incorporates a release feature. This is a small valve adjusted to a set lift and responds to any increase over the set pressure by venting the excess media to atmosphere. It makes possible the re-setting, up or down, from the set pressure whilst the PRV remains in the line. **IT MUST NOT BE REGARDED AS A FULL FLOW CAPACITY RELIEF VALVE!**
- As standard, soft trimmed, un-balanced valve is fitted.
- Internal sealing is achieved with "O" rings.
- Connections for the fitting of pressure gauges are provided on the standard option. (Gauges are available as special option).
- The Inlet/Outlet connections are suitable for mounting into lines of DN20 (nom.).
- It is recommended that connecting pipe-work be suitably supported.
- The valve has M6 tapped holes for panel mounting.
- Approximate weight of the equipment is, for Stainless Steel version, 5Kg. therefore, the equipment may be regarded as portable.

#### 1.1 FUNCTION

With the hand-wheel (12) wound fully **anti-clockwise**, flow is prevented from flowing through the PRV as the main valve (11) is maintained firmly against its seat (30) by spring (16).

**Turning the hand-wheel clockwise loads the spring (40).** This load is applied, via the diaphragm (63) and components of the valve (11) which, once the applied load exceeds that of spring (16), will be forced off its seat (30) allowing media to flow to the outlet and, via the feed hole, to the underside of the diaphragm. When this pressure balances the load generated by the spring (40), the valve will move toward closed until the flow is balanced to maintain the set outlet pressure.

#### On release versions:

Should the outlet pressure rise above the set pressure, the diaphragm (63) will continue to travel upwards until the valve (50) is displaced from its seat. This allows excess media to pass via the vent port to atmosphere. (See also General Notes).

In closed circuits the main valve (11) closes when the set pressure is reached in the system.

#### 2.0 INSTALLATION

**BEFORE COMMENCEMENT OF ANY INSTALLATION WORK, IT IS IMPORTANT THAT ANY SOURCE OF PRESSURISED MEDIA BE TURNED OFF OR ISOLATED FROM THE POINT AT WHICH THE PRV WILL BE INSTALLED. AT ALL TIMES, IT IS ESSENTIAL THAT ISOLATING VALVES MUST BE ACTUATED SLOWLY TO AVOID THE RISK OF EXPLOSION DUE TO DIESELING.**

- Remove packaging and ensure that there are no obviously loose parts or visual signs of damage.

- Check that the information listed on the "DATA LABEL" confirms that the PRV supplied is suitable for the intended service.
- Wind the hand-wheel fully **anti-clockwise** to ensure that the load spring is "off load".
- The system into which the PRV is to be set must be clean and free of any solid inclusion which could be a source of damage to soft seated components.
- The PRV is set directly into the line using the threaded inlet and outlet connections. **CARE SHOULD BE TAKEN WHEN USING ANY FORM OF SEALING TAPE THAT ANY LOOSE FRAGMENTS ARE NOT ALLOWED TO COME INTO CONTACT WITH THE SEATING AREAS OF THE PRV.**
- The two ports are diametrically opposite and it is important that the PRV is correctly oriented into the pipe-work. A "FLOW DIRECTION" arrow is visible on the body. Other than for ease of maintenance, the **ANGULAR** orientation of the PRV in the line is not important.
- The two pressure gauge connections are located at 45° to their respective inlet or outlet port, and are also clearly marked.
- If the media is hazardous, the vent port located in the PRV body, **MUST BE PIPED TO A SAFE DISPOSAL POINT.** (See also General Notes).
- If the PRV is to be panel mounted, it is recommended that the two M6 tapped holes are used..

#### 2.1 SETTING TO WORK

- Ensure that inlet, outlet and pressure gauge connections, if those on the PRV are utilised, are leak-tight. Check with "leak detection" fluid if necessary.
- Ensure that supply and outlet isolation valves are closed.
- **SAFETY NOTE "OPEN AND CLOSE ALL ISOLATING VALVES SLOWLY!"**
- Check that hand-wheel is wound fully **anti-clockwise**, ensuring that the "load spring" is unloaded.
- Gauges must be provided, in line, if they are not mounted direct to PRV, in order that inlet and outlet pressures may be monitored during setting up.
- Ensure that **correct supply pressure** is available, before **SLOWLY** opening supply isolation valve. Outlet isolating valve remains closed. **Turning hand-wheel clock-wise** (See "DIRECTION ARROW" on end of hand-wheel), adjust to required outlet pressure. Monitor pressure on gauge throughout this process. When satisfied that the correct pressure has been set, **VERY SLOWLY** open outlet isolating valve to run system.

#### 3.0 MAINTENANCE

- Having few moving parts, the J46 will require only periodic inspection of those items subject to wear, or deterioration to, ensure long service and reliability. When servicing or repair becomes necessary, it is recommended that the PRV be returned for factory refurbishment. However, the design of the J46 does enable it to be serviced in the field, with minimal inconvenience, to satisfy plant operations and minimise down times. **It is recommended that all repairs and servicing be carried out using only quality assured spares supplied by the manufacturer.**

#### 3.1 PREVENTATIVE MAINTENANCE

- In a clean system, the J46 will continue to deliver trouble free service over long periods of time. Under these conditions, maintenance intervals may be as long as 24-36 months. In more arduous conditions or in aggressive media service, the periods may be

shorter, 6-12 months. It is however, important that units in safety related applications be inspected more frequently. During these preventative maintenance periods, the following procedure is suggested :

- a) Inspect all "O" seals for wear, brittleness or other signs of damage. All those displaying any indication of damage or deterioration should be replaced. However, it is recommended that all seals, regardless of any damages should be routinely replaced.
- b) The valve assembly (11) and seat (30) should be removed and inspected, closely, for wear or other damages. Typical signs of damage will be nicks or raised burrs around the seating edge of the seat (30), or indentations, abrasions and hard particle inclusions in the soft (seating) area of the valve assembly (11). Severe wear and/or very apparent nick's burrs or particle inclusion would indicate that replacement is necessary. Light wear and the presence of a clean, continuous seating ring on both parts would indicate that they are suitable for re-use.
- c) Any components showing signs of corrosion should be inspected for indications of permanent damage (ie. pitting etc.) and replaced if any are present.

### 3.2 REMEDIAL MAINTENANCE

- If the J46 is maintained to a planned program, it is unlikely, unless the system becomes contaminated or an operating system problem causes damage to one of the control elements, that the PRV will malfunction, and the need for remedial service arise. In general it is recommended that damaged PRV's be returned to the factory for repair. To facilitate field repair, and minimise plant down-time, **Table 1.** lists some possible faults and probable causes/solutions. The following recommendations are also made:
- It is preferable that the PRV be repaired or serviced under workshop conditions, as the opened equipment must be protected from ingress of dirt and other foreign material. Should operational requirements make it necessary to service the PRV in the pipe-line, then precautions should be taken to avoid contamination of the unit or parts.
- **SAFETY NOTE: WHEN UNDERTAKING ANY REPAIR OR SERVICING IN WHICH THE PRV REMAINS IN THE LINE, IT IS ESSENTIAL THAT THE EQUIPMENT IS ISOLATED FROM THE PRESSURISED MEDIA, AND THAT ALL ISOLATING VALVES ARE ACTUATED SLOWLY TO AVOID THE RISK OF EXPLOSION THROUGH DIESELING.**

**Table 1.**

SYMPTOM	CAUSE	SOLUTION
Rise in outlet pressure above that set.	Damaged valve (11) and/or seat (30) Dirty valve (11) and/or seat (30) Damaged spring (16) Damaged "O" ring (60)	Replace part(s). Clean part(s). Replace part. Replace part.
Continuous bleed from vent port.	Release incorrectly set. Damaged valve (50) and/or seat (63) Dirty valve (50) and/or seat (63)  <b>OR for DIAPHRAGM VERSIONS:</b> Damaged diaphragm (39)	Re-Adjust. Replace part(s). Clean part(s).  Replace part.

<i>This problem could also be indicated by the causes of rise in set pressure (see above).</i>		
Loss of control in pressure regulation.	Damaged spring (40)	Replace part.

### 4.0 STRIPPING AND RE-ASSEMBLY

Having few parts, stripping and re-assembly of the J46 may be regarded as straightforward, provided certain conditions are observed.

- **SAFETY NOTE: IF THE PRV IS TO BE WORKED ON WHILST REMAINING IN THE PIPE-LINE, IT MUST AT ALL TIMES BE TOTALLY ISOLATED FROM HIGH PRESSURE MEDIA.**
- Cleanliness is of the utmost importance, even the smallest of inclusions may seriously affect the operation of the PRV.
- Tool List:  
M10 Socket – *hand-wheel retaining nut.*  
M4 Hexagon Socket Key.-*spring housing.*  
Adjustable Wrench (up to 25mm. *a/f opening*).-*body plug.*
- Re- assembly should be made using only sparing amounts of grease. That recommended for rubbers is "Dow Corning MS4" and for threads etc. "Bostic Never-Seez", **any alternatives should be checked carefully. Use of lubricants AT ALL with media other than air, MUST BE VERIFIED WITH LUBRICANT SUPPLIERS!**
- **For safety, all tightening torque values must be adhered to.**

### 4.1 STRIPPING

- Remove Plastic Protection Cap (4)
- Remove M10 Nut (10) and Washer (2)
- Lift off Hand-Wheel (12) and Thrust Washer (9)
- Using m4 socket key, remove Spring Housing (1). The Body of the PRV (20) **must be rigidly held for this operation, and care must be exercised to avoid damage to pipe- work if the PRV is to remain in the line for servicing.**
- Once the Spring Housing (1) is clear of its thread, carefully lift clear of the Body (20). The Load Spring (40) should then be lifted from the Body with the spring plate (55), ring (41) (where fitted) and diaphragm (63).
- On Non Release versions the diaphragm plate (56), bush (57), and spring (57) can be removed.
- On Release versions the valve disc (50) can be removed from the valve by pulling out split pin (51).
- The Loading Stem may be removed from the Spring Housing (1), by grasping the M14 thread and pulling it clear. Take care that the *components of the Needle Roller Bearing (6/7) are not allowed to fall and be lost, contaminated, or damaged.*
- To remove the Valve Assembly (11) and Seat (30), it is first necessary to remove the Body Plug (22). The spring (16) and Valve Assembly (11) will be withdrawn with the Bottom Plug. It is possible that the Seat (30) will remain in situ and may have to be removed separately.
- Some difficulty may be encountered in attempting to remove the Valve Assembly (11) and Seat (30), if the PRV **is not mounted in the vertical position (see 2.0).** For ease of handling, it is recommended that the line connections be loosened, and the PRV swung to the **vertical** during servicing.
- On completion of strip down, all parts should be cleaned, using a suitable proprietary cleaner, and dried. Whether the PRV is fully or only partially stripped will depend upon the level of servicing being undertaken. In all cases, parts should be examined as described in

3.1 and 3.2, and those selected for re-use should be stored under clean conditions until required.

### 4.2 RE-ASSEMBLY

- **SAFETY REMINDER: IF THE PRV IS TO BE RE-ASSEMBLED IN THE PIPE-LINE, IT MUST BE FULLY ISOLATED FROM HIGH PRESSURE MEDIA WHILST WORK TAKES PLACE AND UNTIL THE PRV IS SET BACK TO WORK (SEE 2.1). ALL LUBRICANTS MUST BE USED SPARINGLY AND BE APPROVED FOR THE SERVICE MEDIA, FAILURE TO OBSERVE THIS COULD RESULT IN FIRE OR EXPLOSION. ISOLATION VALVES MUST BE ACTUATED SLOWLY TO AVOID DIESELING AND THE RISK OF EXPLOSION.**
- Ensure that all parts are available to complete assembly, and that they are clean and free of damage. It is recommended that all "O" rings be replaced regardless of damages, and that they are smeared sparingly with a suitable lubricant (**see warning note above**). If the PRV is to be re-assembled while in the pipe-line, some difficulty may be encountered when assembling the Seat (10) and Valve Assembly (3). For this reason it is recommended that the PRV be vertically mounted for servicing (**see 4.1**).
- To refit the Seat (30) and Valve Assembly (11). Assemble Body Plug (22) with "O" ring (60), Spring (16) and Valve Assembly (11). Place "O" ring (62) into its groove on Seat (30). The Seat is then placed ("O" ring facing outward) onto the valve assembly, this whole is then carefully screwed into the bottom of the Body (20), and **tightened to 30Nm.**
- On non release versions fit bush (58) spring (57) and diaphragm plate (56).
- On release versions fit disc (50) and split pin (51).
- Both versions. At this point it is easier to assemble the spring housing. First fit o-ring (60) to load stem(3) fit bearing (6&7) and screw on load nut(5)fit load spring (40).
- On non release versions fit spring plate (55), ring (41) (where applicable) and, holding assy. together, place diaphragm(63) in position and push screws (8) through spring housing flange and diaphragm holes.
- This should hold together for attaching to body
- On release versions, procedure is the same except the spring plate is part of the diaphragm assy.
- Finally fit thrustwasher (9) handwheel(12) washer(2)nut(10)and cap(4).
- The PRV is ready to return to work (**see 2.1**).

#### Manufacturer:

**In the event of fire the seals on this valve may become ineffective and/or give off toxic fumes.**

**With respect to unstable and dangerous fluids intended for use with this valve, refer to Transport and Handling sections of the Manufacturers Safety Data Sheet for that fluid or contact Thompson Valves Technical Sales for advice.**

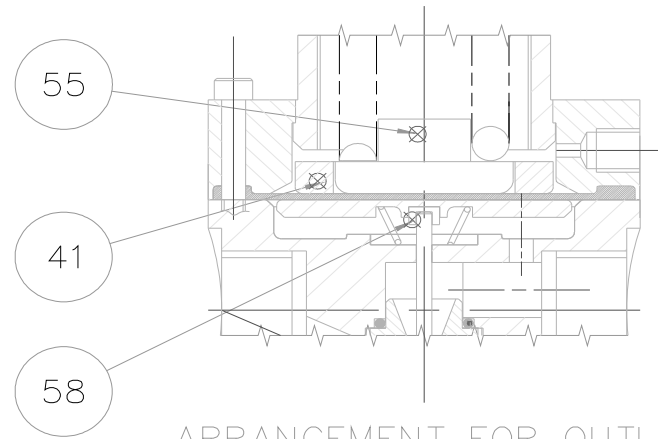

ARRANGEMENT FOR OUTLET  
PRESSURE RANGE 10.5bar–33bar  
AND NO RELEASE OPTION

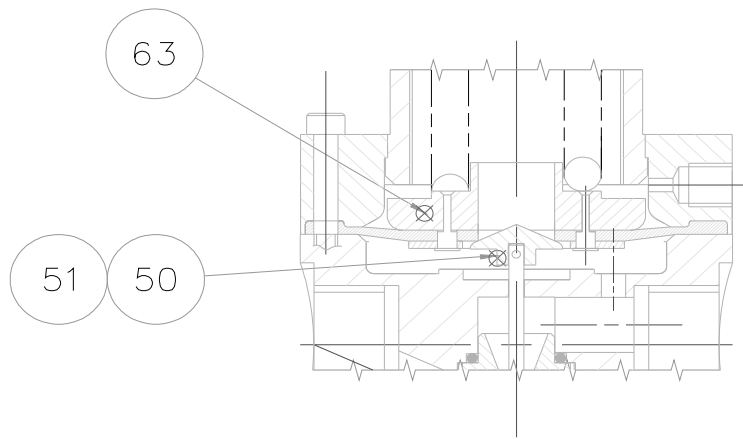

ARRANGEMENT FOR OUTLET  
PRESSURE RANGES UP TO 10.5bar  
AND RELEASE OPTION

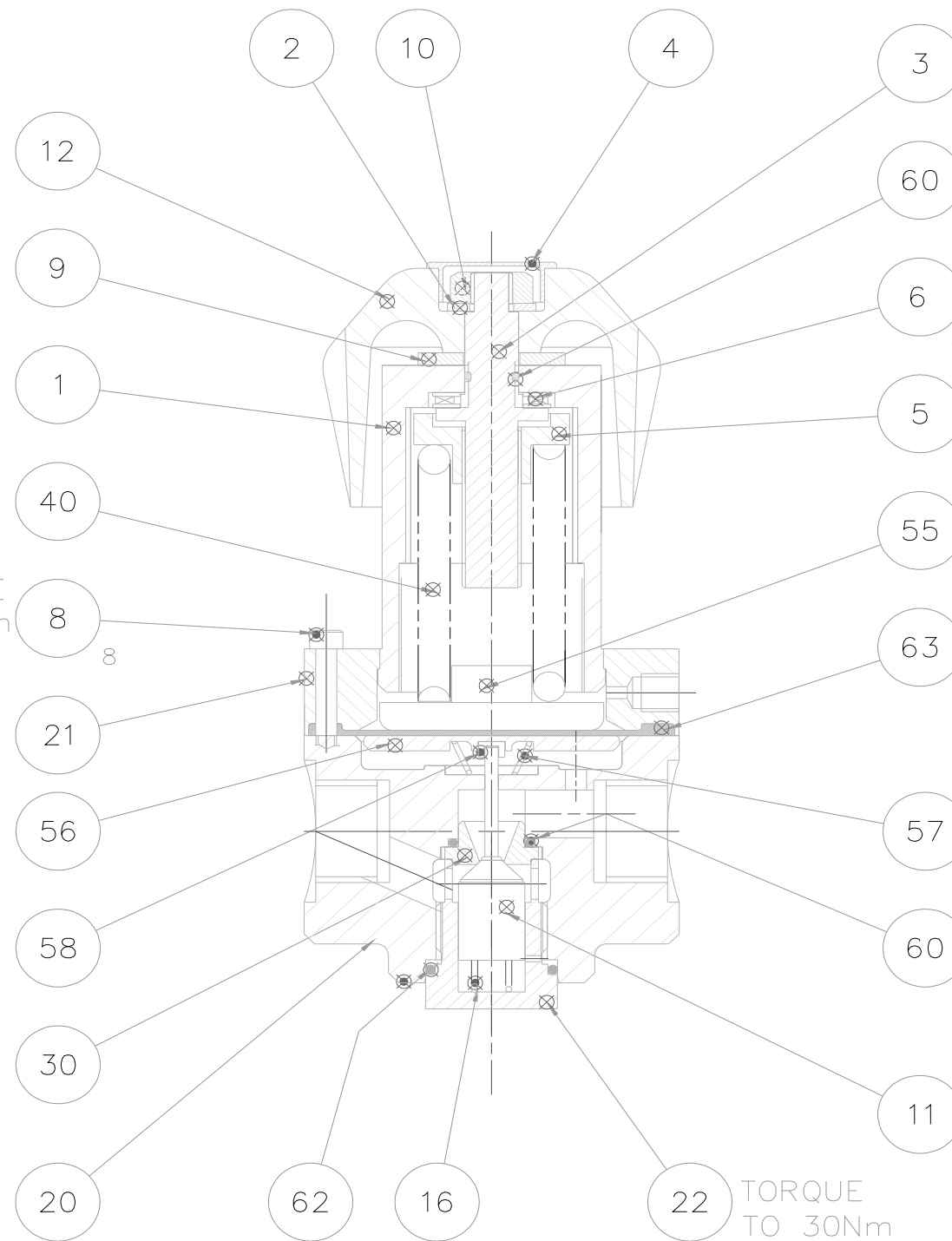
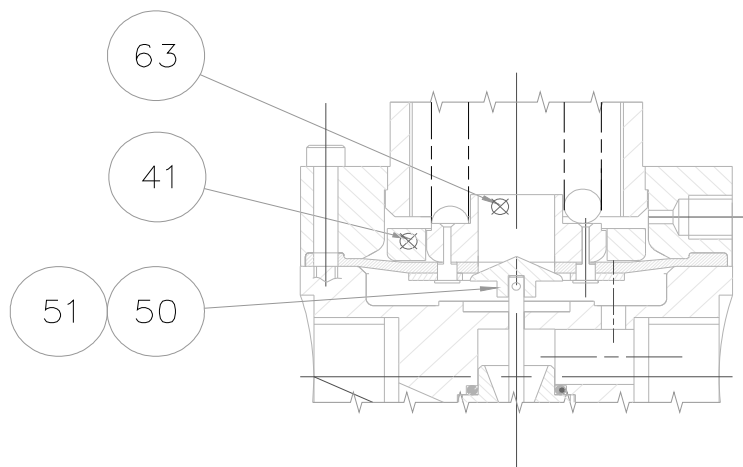

TORQUE  
TO 5Nm

TORQUE  
TO 30Nm

ARRANGEMENT FOR TYPICAL  
PARTS AND OUTLET PRESSURE  
RANGES UP TO 10,5bar  
AND NO RELEASE OPTION